

Integrated PWM module with two current controlled PWM outputs and CAN bus interface for control applications

Features

- 3 PWM outputs 10-30 V
 - 2 current stabilized
 - 1 not stabilized
- galvanically separated inputs and outputs (except analog inputs)
- 3 analog inputs 0-10 V
- 8 V supply output for analog inputs
- 4 digital inputs 10-30 V
 - 1 frequency / duty cycle inputs
- power supply 10-30 V
- CAN bus interface
 - secure MDCAN realtime protocol
 - MDFUNC series compatible
 - MDCAN series compatible
 - NAVIO series compatible
- configurable on-chip software
 - MDFUNC_{I/O} input vs. output matrix
 - select an input out of more than 30 sources for each output channel or link function
 - several automatic control functions (P/PID/RPM)
 - latch function
 - triple station control
 - logic functions
 - transfer function (input vs. output)
 - RS232 interface or USB interface
 - configuration and monitoring with LC display
 - comfort configuration and monitoring with free PC-Tool
 - MDFUNC_{I/O} Tool Version 2.2
 - easy to use
 - more possibilities, more functions
 - firmware upgrades
- status indication by LEDs
- safety feature for AIN channel cable break
- safety feature for CAN bus cable break
- mountable on 35 mm DIN-rail
- max. cable diameter for connectors: 1.5mm² with ferrule

Applications

PWM output module for mobile and marine applications, hydraulic valve controls, motor controls, dimmer controls, input/output CAN bus node.

- control of hydraulic proportional valves
 - bow/stern thruster
 - cylinders
 - winches
 - clutches
 - drives etc.
- position control of hydraulic cylinders
 - steering gears
 - compactors
- pressure control
- central switching
- control of DC-motors

MD engineering GmbH can help to choose the right components and implement your application.

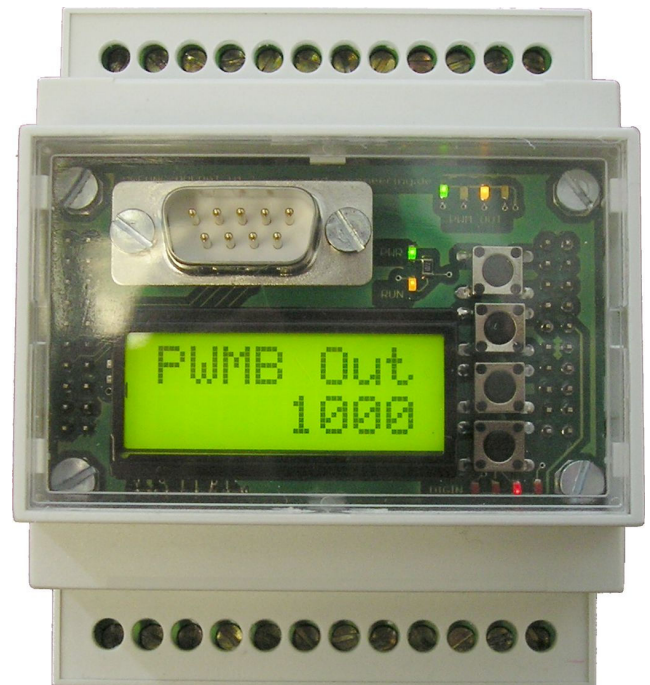

Description

The MDFUNC-PWM3cL can be connected to 3 inductive or resistive loads (e.g. coils). The outputs are driven by proportional PWM. Two of the outputs are **current controlled** (up to 2.5 A) with an adjustable deviance (less than 5 mA are possible). The automatic PI-control offers a fast step response. Additionally a **dither** signal can be added to **avoid sliding friction**.

Three analog, four digital inputs and a CAN-interface are available. One digital input can be used simultaneously for frequency or duty cycle measurements. Inputs can be linked directly to the outputs or to calculation channels making the results available to the CAN bus or useable as a feed back signal.

The MDFUNC-PWM3cL uses the new MDFUNC_{I/O} -engine, which offers more powerful possibilities for creating your control application. Functions like multiple station control, network control or positioning control are pre-programmed and easily accessible.

The onboard LC-display has multiple language support (English, German, Dutch), offers monitoring functions and the possibility to change module parameters. For configuring the module more comfortable, the new MDFUNC_{I/O} PC-Tool is available at the support site. A PC can be connected via RS232 serial port or via USB (hardware option).

Connection diagram

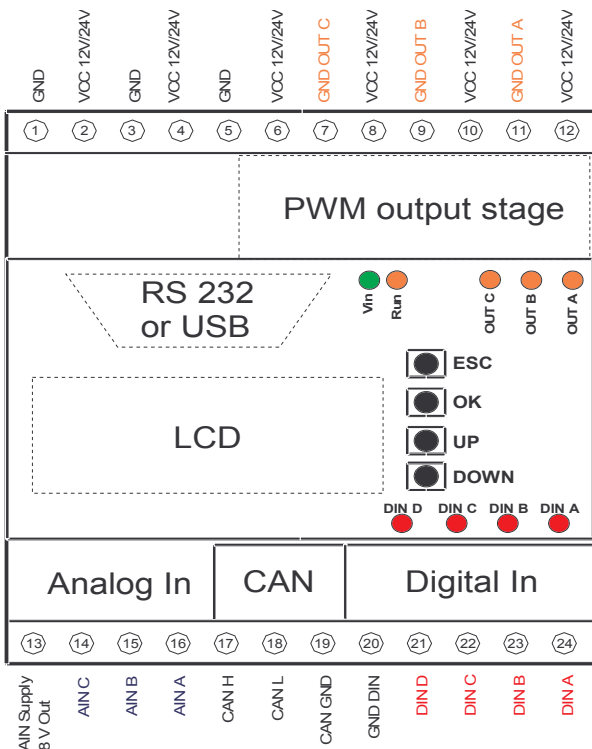

Connector description

supply

1	GND	main system and analog input ground
2	V _{CC MAIN}	main system supply

inputs

17,16,15	AIN A/B/C	analog inputs
14	GND AIN	analog ground, referenz potential for analog inputs and AIN Supply 8V
24,23,22,21	DIN A/B/C/D	digital inputs
20	GND DIN	digital ground, reference potential for digital inputs
18/19	CANH/CANL	CAN bus connectors

outputs

13	AIN Supply 8V	supply for passive analog devices: e.g. joysticks, potentiometers etc.
12,8,6	PWM A/B/C	PWM outputs
3,5,7,9,11	GND PWM	PWM output ground
4,10	V _{CC PWM}	

Button description

- UP/DOWN switch through current menu / in/decrease a value
- OK jump in submenu / select value for edit / accept edited value
- ESC jump out of submenu / cancel value edit

Software assignments

- Output A free, calculation channel
- Output B free, calculation channel
- Output C free, calculation channel
- Output D free, calculation channel
- Output E free, calculation channel

Electrical Characteristics

($T_{env} = 25^{\circ} C$)

Power supply

Symbol	Parameter	min	typ.	max.	abs max.	Unit
V_{In}	system power supply voltage DC	10	12/24	30	32	V
$I_{In} @ 12 V$	system current (with LCD)		180			mA
$I_{In} @ 24 V$	system current (with LCD)		90			mA
T_{env}	environment temperature	-10	25	50	60	$^{\circ}C$

PWM A/B/C

- low side switches
- outputs galvanically separated

Symbol	Parameter	min	typ.	max.	abs max.	Unit
$V_{CC,PWM}$	PWM-stage supply voltage DC	10	12/24	30	40	V
$I_{CC,PWM}$ (both inputs connected)	PWM-stage supply current	-	-	9	13	A
$I_{PWM A/B/C}$	current per channel	20	-	3000	5000	mA
t_{on}	turn on- switching time ³	-	140	-	-	μs
t_{off}	turn off- switching time ³	-	70	-	-	μs
R_{on}	impedance during "on state"	-	30	50	-	m Ω
$f_{PWM,A/B}$ ¹	frequency range channel A and B	1	-	2000	-	Hz
$f_{PWM,C}$ ²	frequency range channel C	15	-	1950	-	Hz

¹ resolution: 1 Hz

² six frequencies available: 15 Hz, 66 Hz, 122 Hz, 244 Hz, 488 Hz, 1950 Hz

³ 10 % $V_{CC,PWM}$ to 90 % $V_{CC,PWM}$ (@ $V_{CC,PWM} = 13 V$)

Digital Inputs A/B/C/D

- inputs galvanically separated

Symbol	Parameter	min	typ.	max.	abs max.	Unit
$V_{DIN,H}$	voltage for high level	3.5	12/24	28	32	V
$V_{DIN,L}$	voltage for low level	-0.5	0	2.5	-	V
$t_{S,DIN}$	turn on/off time (sample time)	-	1	3	-	ms
$I_{DIN} @ 24 V$	current per channel	1.0 ¹	11.0 ²	12	-	mA
f_{DINA}	input frequency range	5	-	5000	7000	Hz
f_{rDINA}	input frequency resolution	1 ³	-	14 ³	-	Hz
Δf_{DINA}	input frequency deviation	-	0.5	2	-	%
$t_{fDINA,stop}$	frequency measurement stop time	200	300	500	-	ms
d_{CDINA} ⁴	input duty cycle range	3.0	-	97.0	-	%
d_{rDINA} ⁴	input duty cycle resolution	0.1	-	0.4	-	%
Δd_{CDINA} ⁴	input duty cycle deviation	-	0.5	3	-	%

¹ @ $V_{DIN} = 3.5 V$

² optocoupler: 5.5 mA, LED: 5.5 mA

³ 1 Hz resolution up to 300 Hz; 14 Hz resolution at 5 kHz

⁴ accuracy of duty cycle measurement depends also on the signal's slew rate and frequency

Analog Inputs A/B/C

- averaged values
- overvoltage protected input

Symbol	Parameter	min	typ.	max.	abs max.	Unit
V_{AIN}	analog input voltage	0	-	10	11	V
R_{AIN}	input impedance	50 ⁴	94	110	-	k Ω
f_{Sample}	internal register update frequency	-	400	-	-	Hz

⁴ input impedance decreases, when V_{AIN} is higher than 11.2 V

AIN supply output

- $V_{\text{sup,AIN}} = 8 \text{ V}$
- $I_{\text{sup,AIN,max}} = 90 \text{ mA}$
- output not galvanically separated

CAN bus interface

- galvanically separated
- connectors with CANH and CANL
- max. bus length: 40 m..1000 m
- selectable CAN bus speed: 50, 125, 250, 500, 1000 kBit/s
- blinking RUN-LED and blinking antenna symbol on LCD, when bus OK
- 3 free 16 bit inputs (MDCAN protocol)
- 3 free 8 bit inputs (MDCAN protocol)
- MDCAN protocol output (10 Hz):
 - analog inputs A/B/C
 - digital inputs (A/B/C/D)
 - frequency input (DINA)
 - latch status results (A/B/C/D/E)
 - output channels (A/B/C/D/E)

RS232 connection

- not galvanically separated
ATTENTION when using PC with grounded outlet power supply GND_{PC} must have the same potential as GND_{PWM3} .
If the difference is more than 100 mV you can damage the PWM3cL and your PC. Best use a laptop powered by battery.
- SUB-D 9 pin male connector on board
- connect common zero modem cable to port (also possible with "USB/RS232" adapter)
- data connection: 57600,8,N,1

USB connection

- not galvanically separated
ATTENTION when using PC with grounded outlet power supply GND_{PC} must have the same potential as GND_{PWM3} .
If the difference is more than 100 mV you can damage the PWM3cL and your PC. Best use a laptop powered by battery.
- Mini-USB connector 5 pin on board
- USB 1.1 standard
- connect PWM3cL with common Mini-USB cable to your PC
- on board USB/RS232 adapter, device will appear as COM-port on your PC
- RS232 data connection: 57600,8,N,1
- driver for free download

Setup Program: MDFUNC-I/O Tool Version 2.2

- more possibilities, better overview
- easy user interface
- free input-output combinations
- inputs from local analog inputs, digital inputs, CAN bus inputs or system outputs for feedback
- boolean operations, latch function
- CAN bus inputs/outputs
- Input vs. Output transfer function
- Ramp functions with gain and offset limitation
- monitor functions
- load/save settings from/to file
- special functions: automatic control, multiple station control
- Requirements:
 - Win2000/XP
 - CPU with 600 MHz or higher
 - COM port or USB port

Package dimensions (in mm)

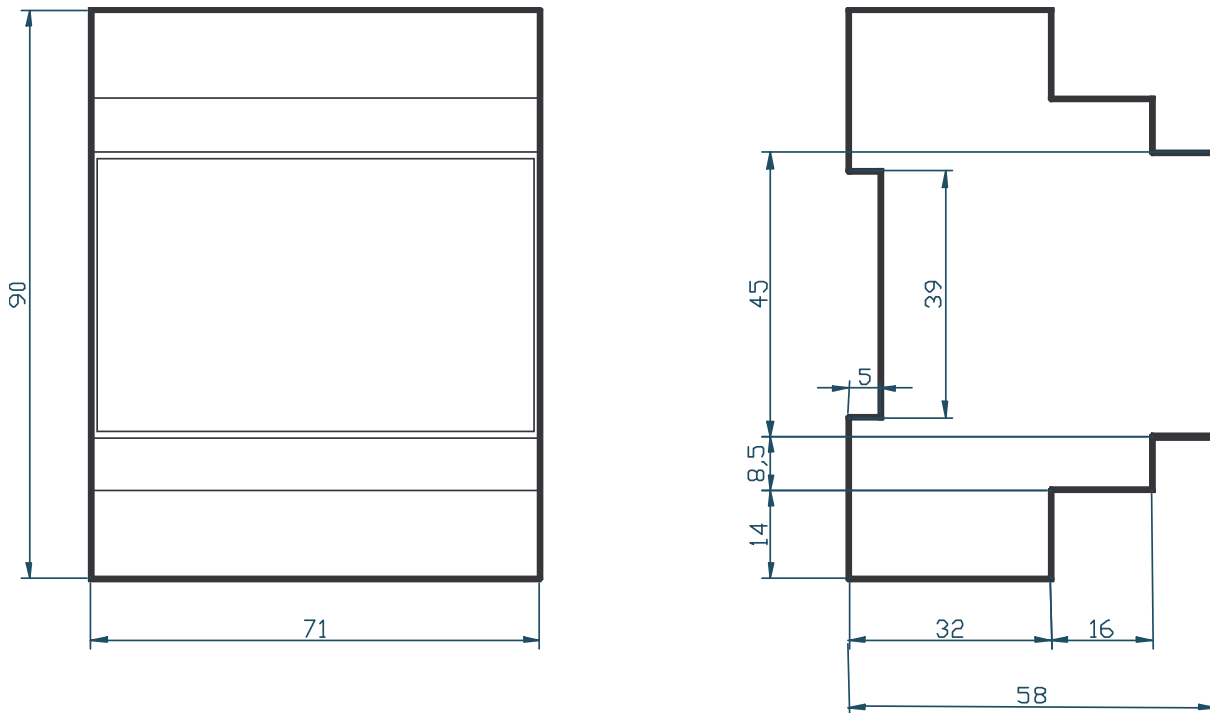

Order codes

PWM3cL with RS232 connector
MDFUNC-PWM3cL-RS232-LCD

PWM3cL with USB-connector
MDFUNC-PWM3cL-USB-LCD

RS232-PC connection cable
MDCABLE-RS232-ZERO

USB-PC connection cable
MDCABLE-MiniUSB

Please ask for special device programming, other CAN protocol stacks or our "low cost solutions" (e.g. not galvanically separated or no LCD).

Support

get datasheets, drivers, firmware, software and examples from:

<http://www.md-engineering.de/produkte/mdfunc/main.html>